

INSTRUCTIONS-PARTS LIST



801-644
Rev C

This manual contains **IMPORTANT WARNINGS** and **INSTRUCTIONS**
READ AND RETAIN FOR REFERENCE

HYDRA-CLEAN® 3245 **Pressure Washer**

P/N 800-066 SERIES A

3200 psi (220 bar) OPERATING PRESSURE

3400 psi (235 bar) MAXIMUM WORKING PRESSURE

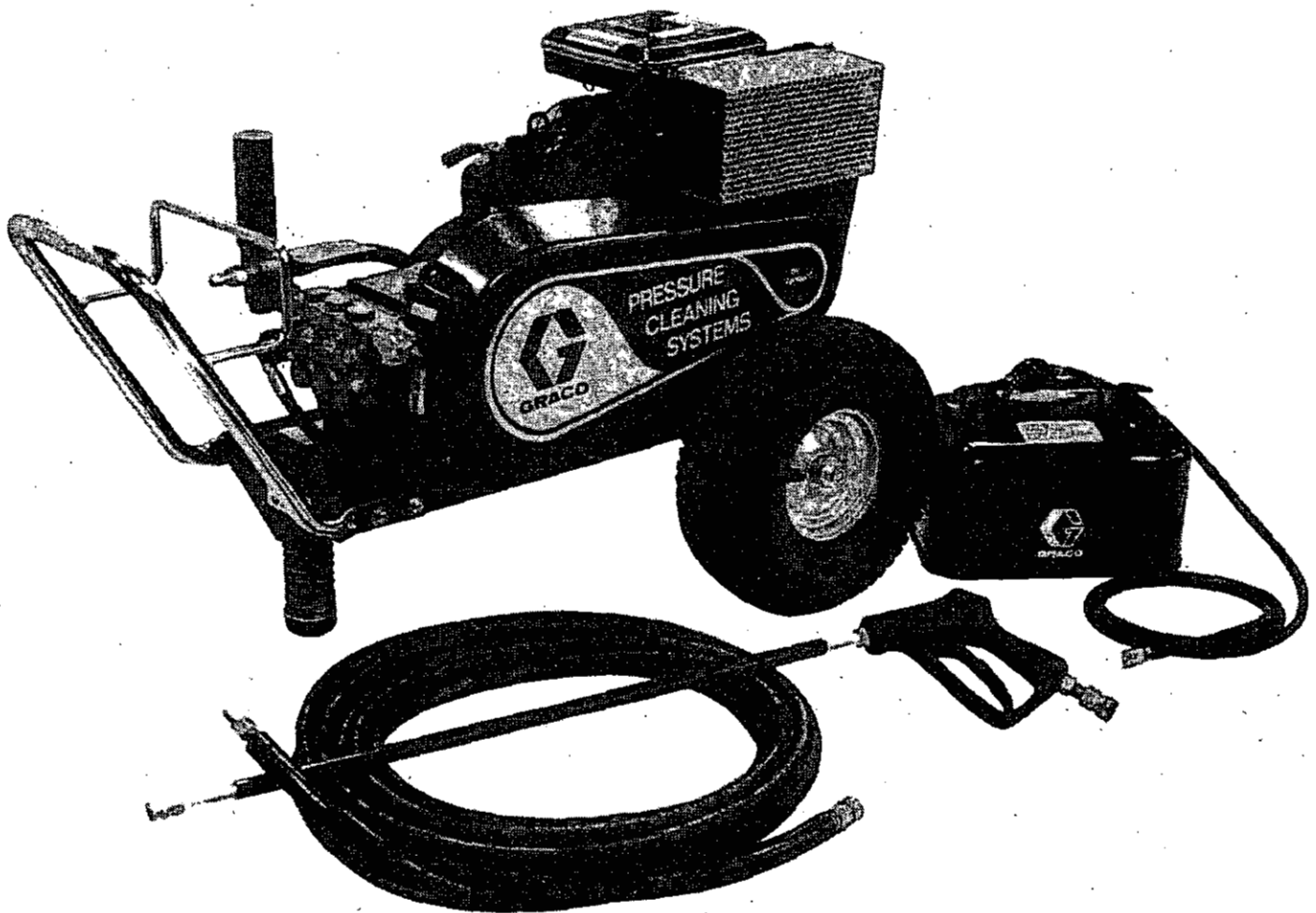

GRACO INC. P.O. Box 1441 MINNEAPOLIS, MN 55440-1444

©COPYRIGHT 1984 GRACO INC.

WARNING

**HIGH PRESSURE SPRAY CAN CAUSE SERIOUS INJURY.
FOR PROFESSIONAL USE ONLY.
OBSERVE ALL WARNINGS.**

Read and understand all instruction manuals before operating equipment.

INJECTION HAZARD

Fluids under high pressure from spray or leaks can penetrate the skin and cause extremely serious injury, including the need for amputation.

NEVER point the spray gun at anyone or any part of the body.

NEVER put hand or fingers over the spray tip.

NEVER try to stop or deflect leaks with your hand or body.

ALWAYS have the tip guard in place when spraying.

MEDICAL TREATMENT

If any fluid appears to penetrate
**EMERGENCY MEDICAL CARE AT ONCE.
DO NOT TREAT AS A SIMPLE CUT.**

Tell the doctor exactly what fluid was injected. For treatment instructions have your doctor call the
**NATIONAL POISON CENTER NETWORK
(412)681-6669**

AVOID COMPONENT RUPTURE

Even after you shut off the gasoline engine, there is high pressure in the pump, hose and gun until you release it by triggering the gun. So before removing the spray tip or servicing the unit, *always* shut off the unit *and* trigger the gun to release pressure.

Be sure that all accessory items and system components will withstand the pressure developed. *NEVER* exceed the pressure rating of any component in system. *NEVER* alter or modify equipment — your personal safety, as well as the function of the equipment, is at stake. Maximum working pressure 3400 PSI (235 bar).

Before each use, check hose for weak, worn or damaged conditions caused by traffic, sharp corners, pinching or kinking. Tighten all fluid connections securely before each use. Replace any damaged hose.

Do not use chemicals or agents which are not compatible with Buna-N and PVC or neoprene cover of hose.

Do not leave a pressurized unit unattended. Shut off the unit and release pressure before leaving.

FIRE

Do not spray flammable liquids. Do not operate the engine where combustible fumes or dust may be present.

GAS ENGINE PRECAUTIONS

NEVER fill fuel tank while engine is running or hot. Avoid the possibility of spilled fuel causing a fire. Always refuel slowly to avoid spillage.

NEVER operate engine in a closed building unless the exhaust is piped outside. The exhaust contains carbon monoxide, a poisonous, odorless and invisible gas, which, if breathed, may cause serious illness or possibly death.

NEVER make adjustments on machinery while it is connected to the engine; first remove the ignition cable from the spark plug. Turning over the machinery by hand during adjusting or cleaning might start the engine and machinery, causing serious injury to the operator.

NEVER run the engine with governor disconnected, or operate at speeds in excess of 3600 RPM load.

Precaution is the best insurance against an accident. When starting the engine, maintain a safe distance from moving parts of the equipment.

GENERAL

NEVER run the unit with the belt guard removed. Keep clear of moving parts when the unit is running.

Observe detergent manufacturer's safety precautions. Avoid getting detergent or other liquids in your eyes. Follow the directions on the container regarding contact with eyes, nose, and skin, breathing fumes, etc. Always wear full goggles to protect your eyes from the spray as well as any debris dislodged by the spray. If necessary, wear gloves or other protective clothing. If antidotes or treatment are recommended, be prepared to use them.

DON'T spray toxic chemicals such as insecticide or weed killer.

IMPORTANT

United States Government safety standards have been adopted under the Occupational Safety and Health Act. These standards — particularly the General Standards, Part 1910, and the Construction Standards, Part 1926 — should be consulted in connection with your use of airless spray equipment.

INSTALLATION

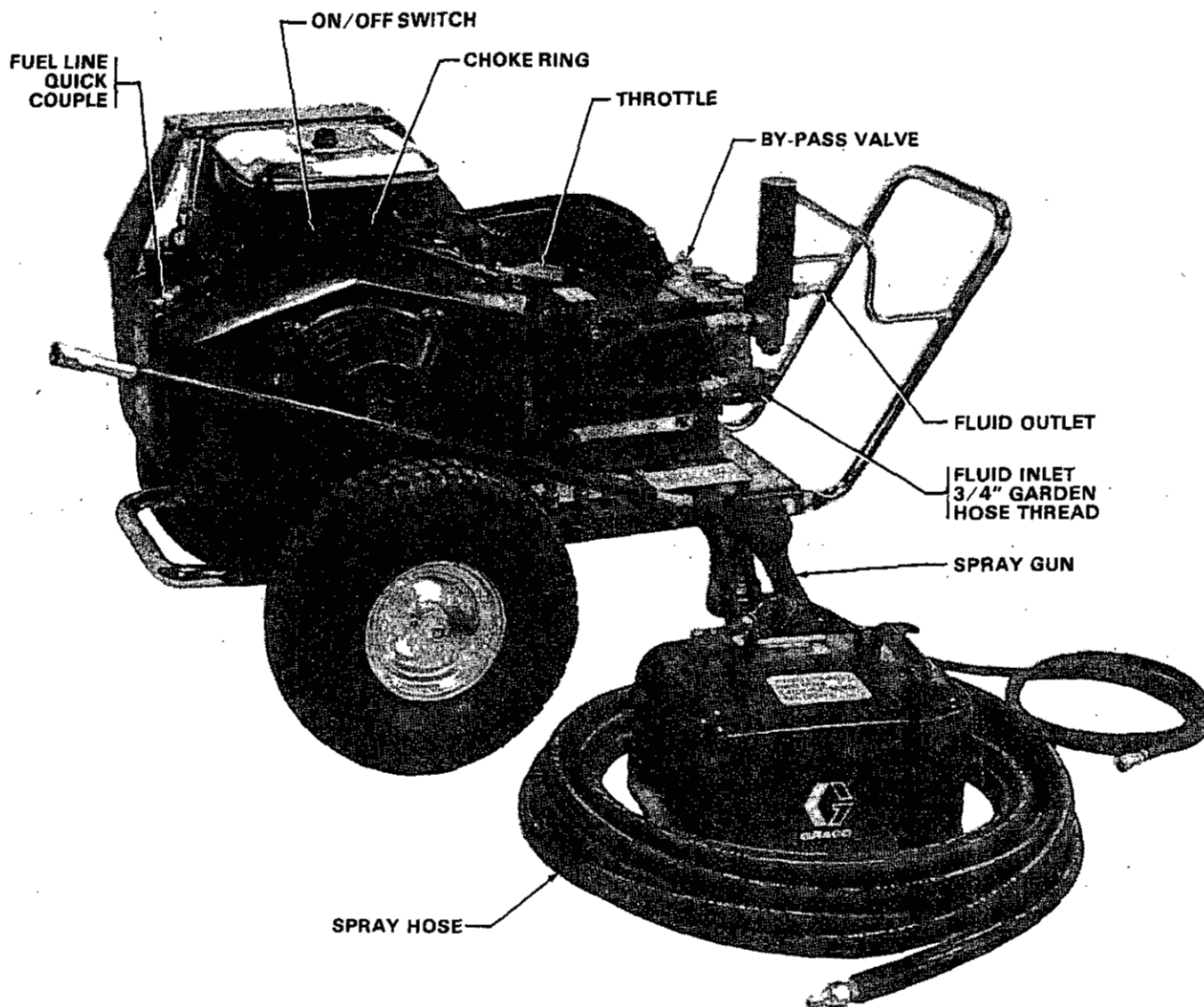

Refer to the engine instruction booklet provided with the unit.

Install Hose and Spray Gun

Connect the spray hose to the spray gun by inserting the pin at the end of the hose into the quick disconnect coupler on the gun. Connect the hose to the fluid outlet in the same way.

Cleaning Accessories

For spraying detergent or other cleaning solution, we recommend using a chemical injector kit. See Accessories and instruction manual 801-645 for installation and operation.

For removing rust and old paint we recommend using a water sandblaster. See Accessories and instruction manual 801-646 for installation and operation.

Connect To Water Supply

CAUTION

Before attaching to water supply, check local plumbing code regarding cross-connection to water supply.

Do not exceed 160°F (70°C) water temperature to pump in a direct supply system.

Connect a hose with at least a 3/4 in. (19 mm) ID from your city water supply to the unit's 3/4 in. garden hose threaded inlet. The supply hose should not be more than 50 ft. (15 m) long.

NOTE: For a direct supply system, your water source at the unit *must* have a flow rate of **AT LEAST 5 GPM (19 LITER/MIN)**.

If your operating conditions are different from above, contact our Customer Service Department for assistance.

OPERATION

Startup

Before starting, be sure to read the safety warnings and setup instructions.

Check the oil and gasoline levels.

Turn on the water supply.

Trigger the gun.

Open the by-pass valve located on the pump.

WARNING

DO NOT wire or tie the gun trigger into the open or triggered position.

Open vent on fuel tank cap. Connect fuel line from tank to engine fuel coupling. Prime gas line by squeezing bulb in line three to five times. Advance throttle control to the start position.

WARNING

Fuel tank must be below unit.

Turn ON/OFF switch (located under the engine air cleaner) to the ON position. Grasp the starter cord handle, put your foot on the frame or wheel to steady the unit, pull the cord rapidly out two or three feet. Repeat if necessary with the choke ring pulled out. When engine fires and begins to run, push choke ring back in. Close by-pass valve on pump.

CAUTION

Never run the cleaning unit dry. Costly damage to the pump will result. Always be sure water supply is completely turned on before operating.

Inspect all connections for any leaks. Tighten if necessary.

Cleaning

For Hydra-Clean technique, see the Chemical Injector manual, 801-645.

For abrasive cleaning, see the Water Sandblaster manual, 801-646.

WARNING

Follow these precautions when removing and installing nozzles:

1. Shut off the cleaning unit and trigger the gun to relieve pressure. Engage the trigger safety.
2. Keep the nozzle and the tube pointed away from you and everyone else.
3. Do not put your hand over the tip to push the nozzle into place. Grasp it from the side and keep your fingers away from the tip.
4. Do not let anyone else touch the spray valve while you are cleaning nozzles.
5. Be sure the slip ring is pushed forward to lock the nozzle in place before triggering the spray gun.

Shutdown and Care Of Unit

When unit is not in use, turn off water supply.

When shutting down for the day or weekend, shut off unit, shut off water supply valve, and trigger gun to release pressure. Wipe off the unit with a damp rag.

CAUTION

Shut off cleaning unit when not actually spraying, for longer pump life. The pump will overheat if left running for over 10 minutes without spraying.

Check the filter screen in the water inlet connection as often as necessary, at least daily. Do not operate the unit with the inlet and filter screen removed.

DO NOT try to adjust the unloader valve. Changing the setting may cause excessive pressure, intermittent unloader operation and increased wear on parts and will void the warranty.

PUMP MUST NOT BE RUN DRY and must be drained of water prior to exposure to freezing temperatures. Use and store the unit where it will not be subjected to freezing temperatures. If water does freeze in the unit, thaw before trying to start. A 50% anti-freeze solution may be pumped prior to cold weather storage.

Use only spray tips that are matched to the unit to avoid excessive cycling and wear of the unloader valve. See ACCESSORIES.

CAUTION

Let a frozen pump thaw in a warm place. Don't pour hot water on a frozen pump. A sudden temperature change may crack the ceramic plungers.

Do not pump caustic materials.

Before extended storage, flush the pump with light oil.

Avoid dragging hose over an abrasive surface such as cement. This causes excessive wear and shorter hose life.

Clean the intake line strainer daily.

Lubrication and Care

Change the engine oil after every 100 hours of operation. Drain oil with engine warm. Engine requires 3 pints (1.4 liters) 30W oil. See separate instruction manual for maintenance procedures.

Fill pump crankcase to dot on oil gauge window with 34 oz. (1.0 liters) of crankcase oil (part no. 801-144) or equivalent SAE 40 weight hydraulic oil with anti-wear and rust inhibitor additives. Change initial fill after 50 hour running period. Change oil every 3 months or at 500 hour intervals.

WARNING

NEVER alter adjustment or modify the unloader valve.

Altering or adjusting unloader will not increase performance of unit.

Service of the unloader must be performed only by qualified service personnel.

SERVICE

TROUBLESHOOTING

PROBLEM	CAUSE	SOLUTION
Engine Will Not Start Or Hard To Start.	No gasoline in fuel tank or carburetor. Water in gasoline or old fuel. Choked improperly. Flooded engine. Dirty carburetor air filter. Spark plug dirty or improper gap. Spray gun closed.	Fill the tank with gasoline, open fuel shut-off valve. Check fuel line and carburetor. Drain fuel tank and carburetor. Use new fuel and dry spark plug. Open choke and crank engine several times to clear out the gas. Remove and clean. Clean, adjust the gap or replace. Trigger spray gun.
Engine Misses Or Lacks Power	Partially plugged air filter. Spark plug dirty, wrong gap, or wrong type. Incorrect ignition timing.	Remove and clean. Clean, adjust the gap, or replace. Time engine.
Low Pressure	Worn nozzle. Belt slippage. Air leak in inlet plumbing. Relief valve stuck, partially plugged or improperly adjusted; valve seat worn. Inlet suction strainer clogged or improper size. Worn packing. Abrasives in pumped fluid or severe cavitation. Inadequate water supply. Fouled or dirty inlet or discharge valves. Worn inlet or discharge valves. Leaky discharge hose	Replace with nozzle of proper size. Tighten or replace; use correct belts and replace both at same time. Disassemble, reseal, and reassemble. Clean, and adjust relief valve; check for worn and dirty valve seats. Kit available. Clean. Use adequate size. Check more frequently. Install proper filter. Check flow available to pump. Clean inlet and discharge valve assemblies. Replace worn valves, valve seats and/or discharge hose.
Pump runs extremely rough, pressure low.	Restricted inlet or air entering the inlet plumbing. Inlet restrictions and/or air leaks. Stuck inlet or discharge valve. Leaking H.P. seals.	Proper size inlet plumbing; check for air tight seal. Clean out foreign material, replace worn valves. Replace seals.
Water leakage from under the manifold.	Worn packing.	Install new packing.
Water in pump crankcase.	May be caused by humid air condensing into water inside the crankcase.	Change oil at 3 month or 500 Hour intervals using Crankcase Oil (other approved oil every month or 200 hours) P.N. 801-144.
Frequent or premature failure of the packing.	Scored plungers. Over pressure to inlet manifold. Damaged or worn plungers. Abrasive material in the fluid being pumped. Excessive pressure and/or temperature of fluid being pumped. Over pressure of pumps. Running pump dry.	Replace plungers. Reduce inlet pressure. Replace plungers. Install proper filtration on pump inlet plumbing. Check pressures and fluid inlet temperature; be sure they are within specified range. Reduce pressure. Do not run pump without water.
Strong surging at the inlet and low pressure on the discharge side.	Foreign particles in the inlet or discharge valve, or worn inlet and/or discharge valves.	Check for smooth lap surfaces on inlet and discharge valve seats. Discharge valve seats and inlet valve seats may be lapped on a very fine oil stone.

PARTS DRAWING
Pressure Washer Assembly, 800-066

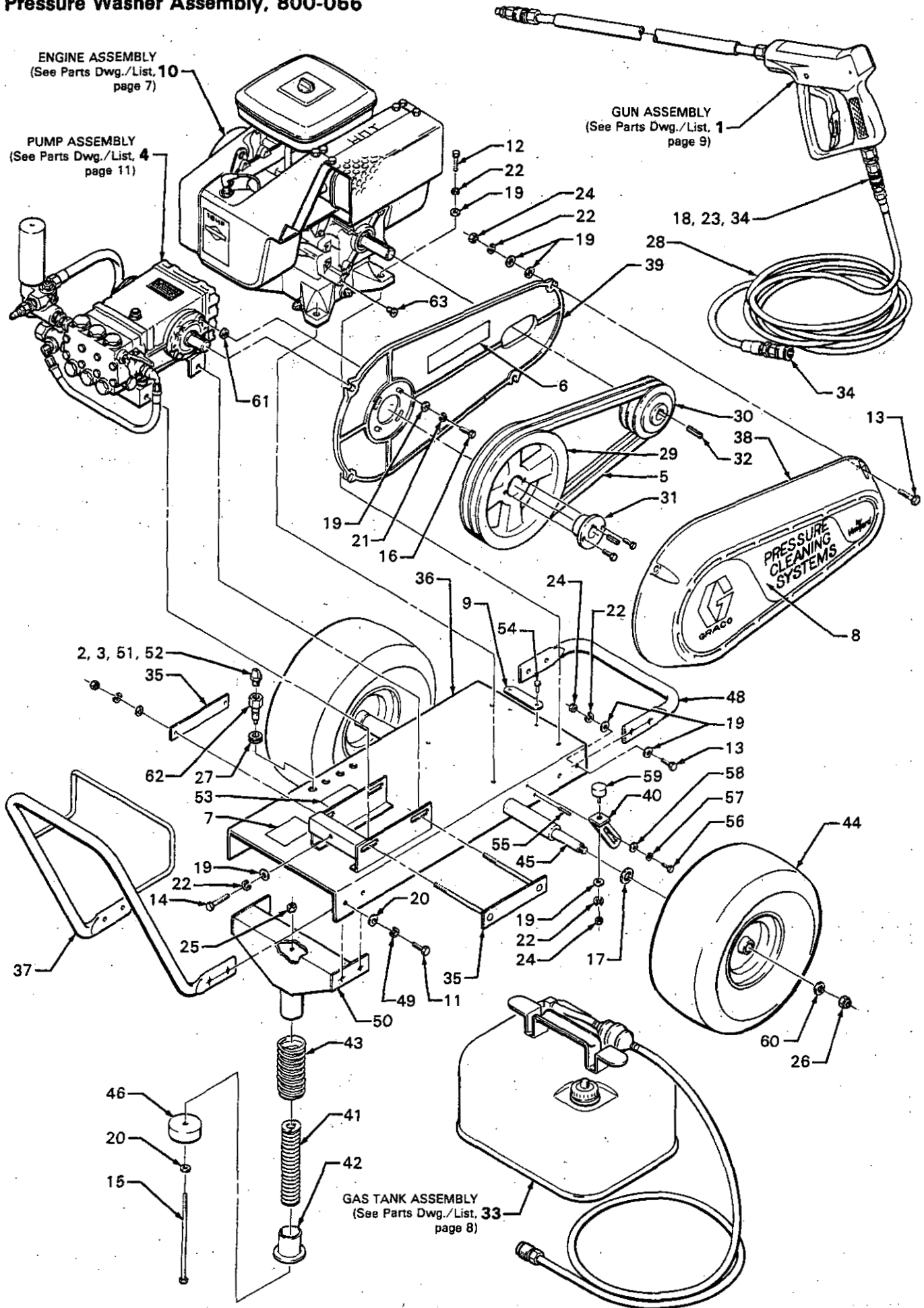

PARTS LIST

Pressure Washer Assembly, 800-066

REF. PART NO. NO.	DESCRIPTION	QTY	REF. PART NO. NO.	DESCRIPTION	QTY
1 800-130	GUN ASSEMBLY, see parts drawing/list page 9	1	32 801-137	KEY, pulley	1
2 *801-640	TIP, 0005 MEG, 1/4 thd.	1	33 800-083	GAS TANK ASSEMBLY, see parts drawing/list page 8	1
3 *801-667	TIP, 1505 MEG, 1/4 thd.	1	34 *801-569	QUICK COUPLE, male	2
4 800-059	PUMP ASSEMBLY, see parts drawing/list page 11	1	35 800-058	RAIL STIFFNER WELDMENT	1
5 801-616	BELT, drive	2	36 800-082	CHASSIS WELDMENT	1
6 801-141	LABEL, warning	1	37 801-541	HANDLE	1
7 801-129	LABEL, warning	1	38 801-618	BELTGUARD COVER	1
8 801-543	DECAL, Graco/Vanguard	1	39 801-619	BELTGUARD BASE	1
9 801-131	PLATE, serial no.	1	40 801-609	BRACKET, support	1
10 800-084	ENGINE ASSEMBLY, 18 h.p., see parts drawing/list page 7	1	41 801-507	SPRING	1
11 801-546	SCREW, hex, 3/8-16 x 1-1/2"	4	42 801-505	FOOT RETAINER	1
12 801-088	SCREW, hex, 5/16-18 x 1-1/2"	4	43 801-506	BOOT, leg	1
13 801-302	SCREW, hex, 5/16-18 x 1"	8	44 801-550	WHEEL	2
14 801-517	SCREW, hex, 5/16-18 x 3"	1	45 801-538	AXLE	1
15 801-589	SCREW, hex, 3/8-16 x 7"	1	46 801-504	FOOT	1
16 801-559	SCREW, hex, M8 x 30 MM	4	48 801-539	BUMPER	1
17 801-547	BUSHING, mach., 3/4	2	49 801-363	WASHER, lock, 3/8	4
18 801-603	NIPPLE, hex, 3/8 x 3/8 NPT	1	50 801-537	WELDMENT, leg support	1
19 801-023	WASHER, flat, 1/4	26	51 *801-614	TIP, 2505 MEG, 1/4 thd.	1
20 801-015	WASHER, flat, 5/16	5	52 *801-615	TIP, 4005 MEG, 1/4 thd.	1
21 801-139	WASHER, lock, 1/4	4	53 801-130	LABEL, warning	1
22 801-025	WASHER, lock, 5/16	14	54 801-132	RIVET, drive	2
23 *801-568	QUICK COUPLE, male, 3/8	1	55 801-608	PIN, roll	1
24 801-024	NUT, hex, 5/16-18	9	56 801-605	SCREW, hex, #10-24 x 3/4	1
25 801-499	NUT, locking, 3/8-16	1	57 801-607	WASHER, lock, #10	1
26 801-020	NUT, locking, 1/2-13	2	58 801-606	WASHER, flat, 3/16	1
27 801-548	GROMMET	4	59 801-369	BUMPER	1
28 801-571	HOSE, H.P., 3/8 x 50 ft.	1	60 801-612	WASHER, flat, 7/16	2
29 801-004	PULLEY, pump	1	61 801-576	SPACER, beltguard	4
30 801-617	PULLEY, engine	1	62 801-090	QUICK COUPLE, female thd.	4
31 801-376	HUB, pulley	1	63 801-680	BUMPER, rubber	1

Order parts by name and series letter of the assembly for which you are ordering.

*Recommended "tool box" spare parts.

PARTS DRAWING

Engine Assembly, 800-084

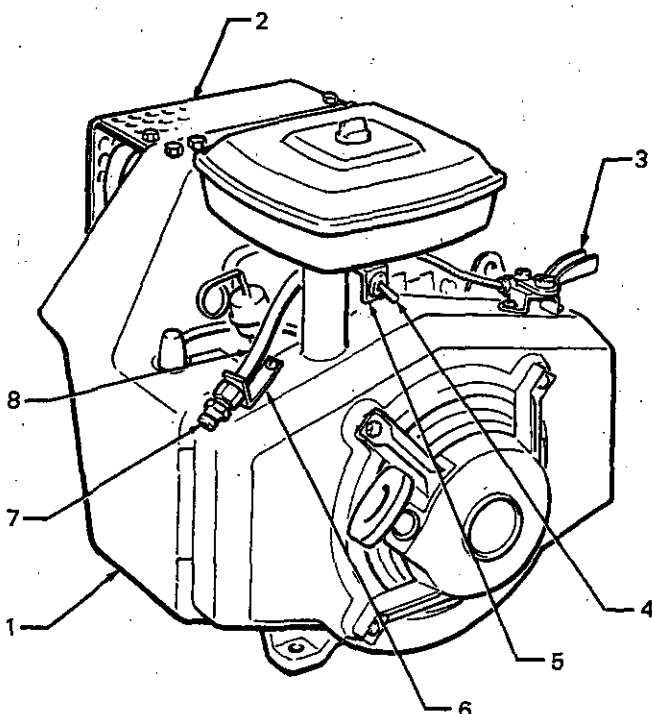

PARTS LIST

Engine Assembly, 800-084

REF. PART NO. NO.	DESCRIPTION	QTY
1 801-628	ENGINE, 18 H.P.	1
2 801-719	HEAT SHIELD EXTENSION	1
3 801-585	THROTTLE CONTROL	1
4 801-626	SWITCH	1
5 801-627	BRACKET, switch	1
6 801-635	FUEL BRACKET	1
7 801-634	QUICK COUPLE	1
8 801-629	FUEL LINE	1

Order parts by name and series letter of the assembly for which you are ordering.

PARTS DRAWING
Gas Tank Assembly, 800-083

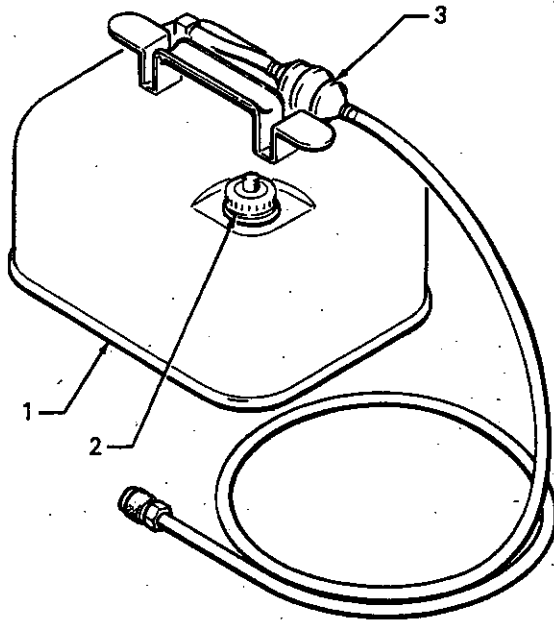

PARTS LIST
Gas Tank Assembly, 800-083

REF. PART NO.	NO.	DESCRIPTION	QTY
1	801-577	TANK, gas	1
2	801-578	CAP	1
3	801-579	FUEL LINE KIT	1

Order parts by name and series letter of the assembly for which you are ordering.

PARTS DRAWING
Unloader Assembly, 800-122
3000 PSI (207 bar) Max.

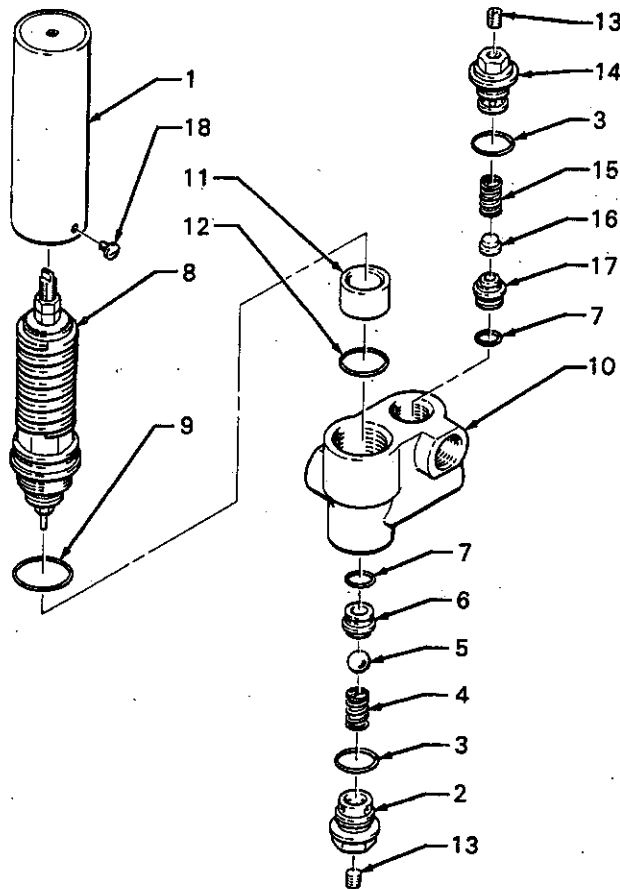

PARTS LIST
Unloader Assembly, 800-122

REF. PART NO.	NO.	DESCRIPTION	QTY
1	800-044	SLEEVE ASSEMBLY	1
2	801-045	CAGE, valve	1
3	801-046	O-RING	2
4	801-047	SPRING	1
5	801-048	BALL	1
6	801-049	SEAT	1
7	801-050	O-RING	2
8	800-123	UNLOADER SUB-ASSEMBLY	1
9	801-059	O-RING	1
10	801-412	HOUSING	1
11	801-432	CYLINDER	1
12	801-062	O-RING	1
13	801-063	PLUG	2
14	801-068	HOUSING VALVE	1
15	801-069	SPRING	1
16	801-070	VALVE	1
17	801-071	SEAT	1
18	801-465	SCREW, button hd, #6-32 NC x 5/16"	2

Order parts by name and series letter of the assembly for which you are ordering.

PARTS DRAWING
Gun Assembly, 800-130

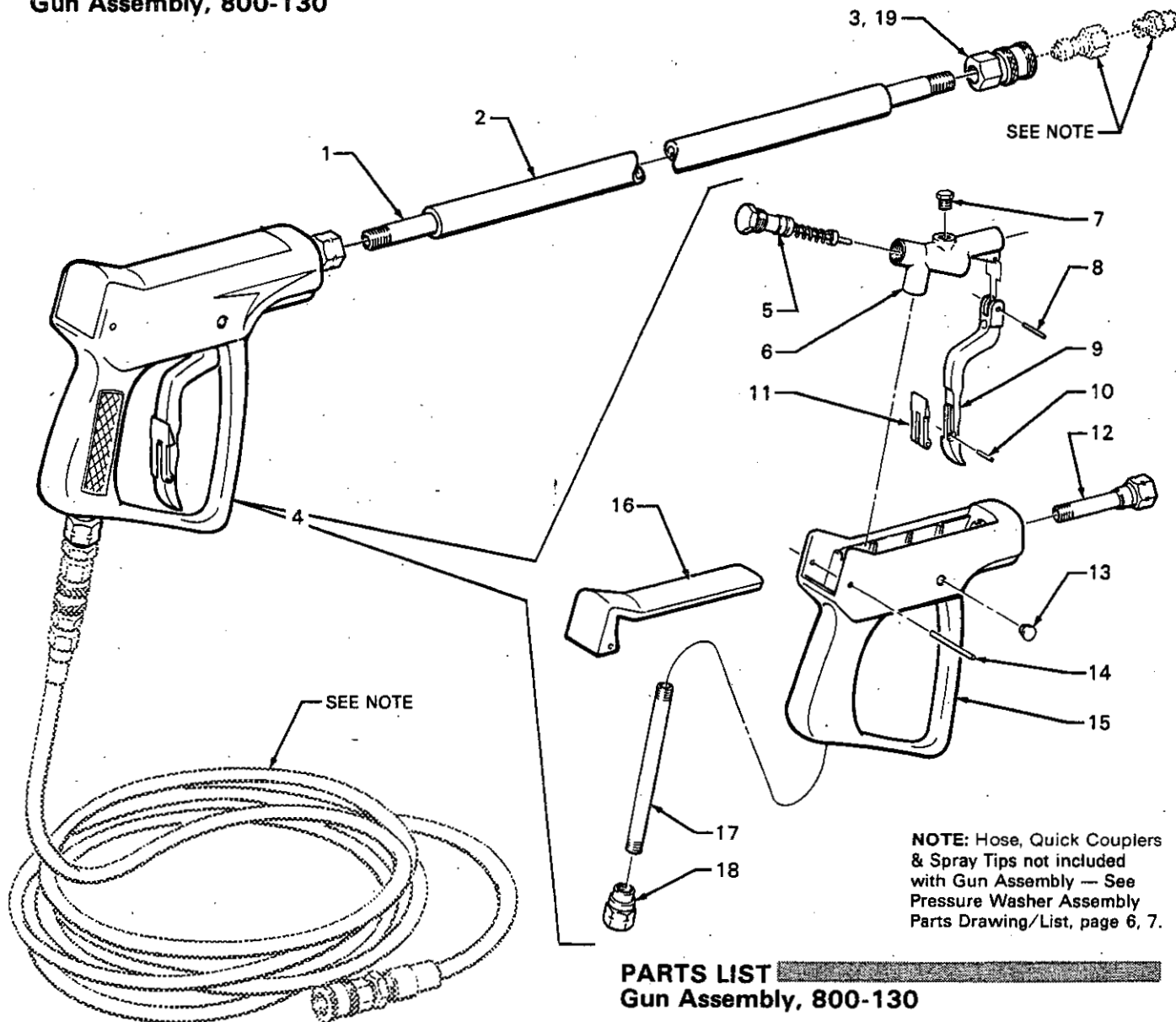

NOTE: Hose, Quick Couplers & Spray Tips not included with Gun Assembly — See Pressure Washer Assembly Parts Drawing/List, page 6, 7.

PARTS LIST
Gun Assembly, 800-130

SERVICE
Gun, Cartridge Replacement

1. Press access pin (14) from gun handle and remove access plate (16) by sliding plate backwards. Remove cartridge (5) from housing (6) by using a 19 mm socket wrench.
2. Check inside housing to be sure all o-rings came out when cartridge was removed. If o-ring can be seen inside the housing, remove it, being careful not to damage internal threads in housing.
3. Throw away old cartridge and install new cartridge using a small amount of pipe sealant on threads. Be sure to tighten cartridge firmly against housing.
4. Slide access plate into place and install access pin.

REF. PART NO.	NO.	DESCRIPTION	QTY
1	801-134	TUBE, 32"	1
2	801-674	GRIP	1
3	801-009	COUPLER, female quick disconnect	1
4	801-638	SPRAY GUN, (replaceable parts include items 5-18)	1
5	801-639	CARTRIDGE	1
6	801-671	HOUSING	1
7	801-670	HEX PLUG	1
8	801-256	TRIGGER PIN	1
9	801-424	TRIGGER	1
10	801-426	LATCH PIN	1
11	801-425	SAFETY LATCH	1
12	801-672	OUTLET	1
13	801-673	PIN COVER	2
14	801-428	ACCESS PIN	1
15	801-419	HANDLE	1
16	801-427	ACCESS PLATE	1
17	801-420	TUBE	1
18	801-423	INLET FITTING	1
19	*801-202	O-RING, quick couple	1

Order parts by name and series letter of the assembly for which you are ordering.

*Recommended "tool box" spare parts.

SERVICE

Pump (Refer to Parts Drawing, Page 11)

NOTE: Two sizes of metric wrenches are necessary for servicing the pump; M13 and M30.

Valves:

1. Remove the hex plug (5) from manifold (6) using M30 wrench.
2. Examine o-ring (4) under plug and replace if cuts or distortion exist.
3. Remove valve unit and o-ring (3) from cavity.

NOTE: Valve unit may come apart during removal.

4. Replace valve unit with P/N 801-472.
5. Replace hex plug and torque to 75 ft. lbs. (10.3 K/m).

NOTE: Hex plug should be re-torqued after 5 hours operation.

Pumping Section:

1. Remove the eight cap screws (1) from the manifold using the M13 wrench.
2. Carefully separate the manifold from the crankcase.

NOTE: It may be necessary to tap manifold lightly with mallet to loosen.

CAUTION

Keep manifold properly aligned with ceramic plungers when removing to avoid damage to plungers or seals.

3. Carefully examine each plunger (16) for any scoring and replace if necessary.

Servicing Plungers:

1. Loosen plunger retaining screw (12) 5-6 turns, using M-10 wrench. Push plunger towards crankcase. This will separate plunger and retaining screw.
2. Remove retaining screw from plunger and examine o-ring (18), back-up ring (17), and copper bearing/gasket washer (13). Replace if necessary using plunger repair kit P/N 801-474.
3. Remove plunger from plunger rod and remove copper flinger (15). Clean or replace if necessary.
4. Lightly grease flinger and replace it on plunger rod.
5. Replace plunger.
6. Lightly grease retaining screw assembly to avoid cutting o-ring. Lightly grease outer end of plunger.
7. Install retaining screw assembly into plunger and torque to 14.4 ft. lbs. (2 K/m).

8. Lubricate each plunger and carefully slide manifold onto crankcase.

9. Replace the eight capscrews and snug them up. Torque to 21.7 ft. lbs. (3 K/m).

NOTE: The eight capscrews must be torqued evenly to apply equal pressure on the manifold so that it seats properly and doesn't bind or jam. This is best done by torquing bolts closest to the center of the manifold first and then working out from those bolts.

Servicing V-Packings:

NOTE: Use packing repair kit P/N 801-486.

1. After removing the eight capscrews and the manifold carefully pull packing retainer (19) from the manifold. Examine o-ring (10) and replace if necessary.
2. Remove low pressure packing (8) and head ring (7).
3. Pull intermediate retainer ring (20) from manifold. Remove long life ring (9), high pressure packing (8) and head ring (7).

4. Inspect all parts and replace if necessary.

NOTE: If just the packings are needed use kit 801-486. If rings or retainers need replacement use kit 801-487.

5. Thoroughly clean packing cavity in manifold and examine. Lightly grease packing cavity.
6. Replace packing assembly in the following order: head ring (7), packing (8), long life ring (9), intermediate ring (20), head ring (7), packing (8), packing retainer (19), and o-ring (10).

CAUTION

Carefully study the location of each part and the position of the seals to assure proper reassembly and operation.

7. Lubricate each plunger and carefully slide manifold onto crankcase.

NOTE: When replacing the manifold onto plungers, extreme caution should be exercised to avoid damage to the seals.

8. Replace the eight capscrews in the manifold and tighten as previously described (step 9 under servicing plungers).

PARTS DRAWING
Pump Assembly, 800-059

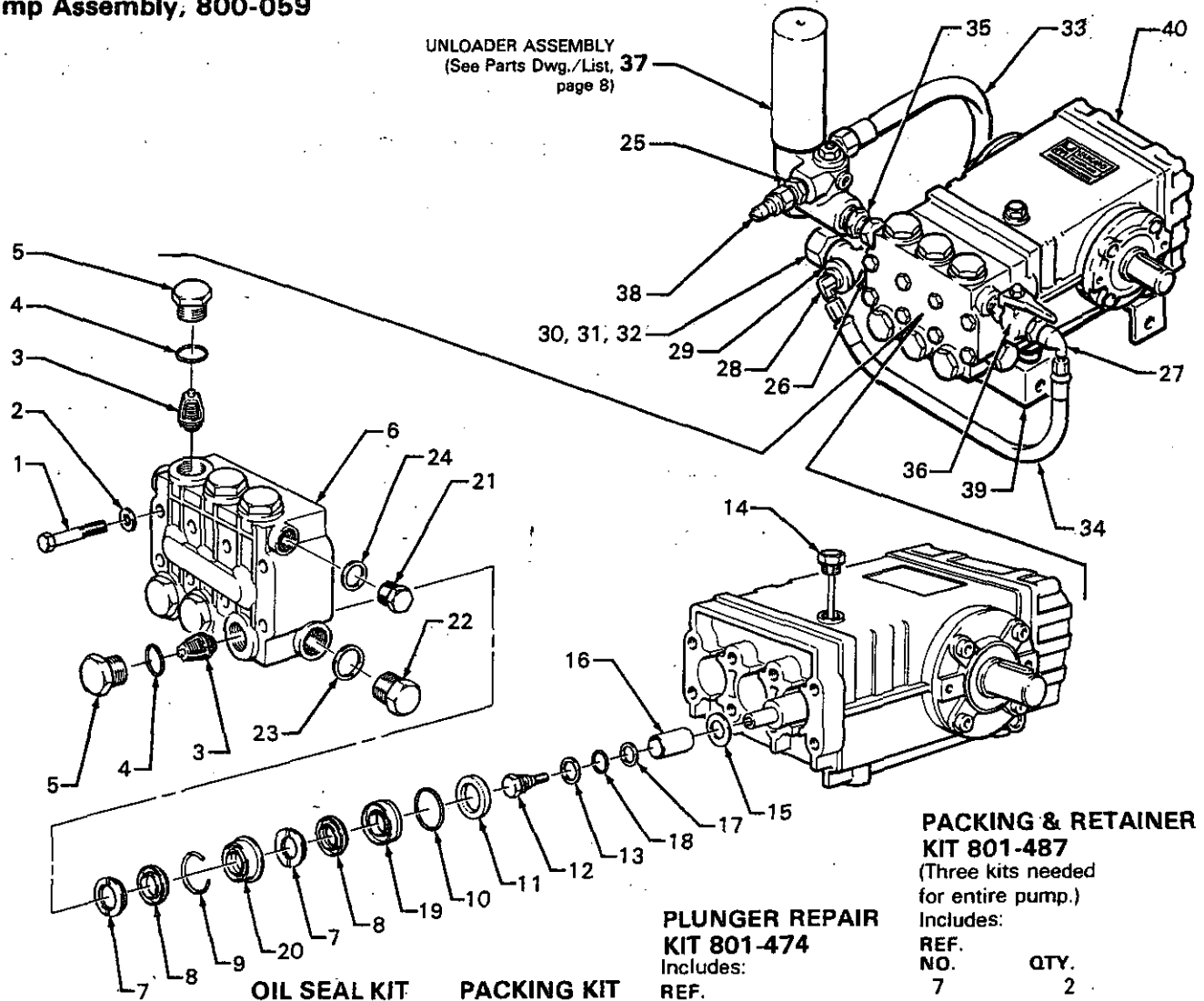

UNLOADER ASSEMBLY
 (See Parts Dwg./List, 37
 page 8)

**PACKING & RETAINER
 KIT 801-487**
 (Three kits needed
 for entire pump.)
 Includes:

**PLUNGER REPAIR
 KIT 801-474**
 Includes:

**OIL SEAL KIT
 801-473**
 Includes:

REF. NO.	QTY.
11	3

**PACKING KIT
 801-486**
 Includes:

REF. NO.	QTY.
8	6

REF. NO.	QTY.
12	3
13	3
17	3
18	3

REF. NO.	QTY.
7	2
8	2
9	1
10	1
19	1
20	1

PARTS LIST
Pump Assembly, 800-059

REF. NO.	PART NO.	DESCRIPTION	QTY	REF. NO.	PART NO.	DESCRIPTION	QTY
1	801-468	SCREW, M8 x 70 mm	8	22	801-482	CAP, 1/2 NPT	1
2	801-469	WASHER	8	23	801-483	WASHER	1
3	801-472	VALVE UNIT	6	24	801-485	WASHER	1
4	801-470	O-RING	6	25	801-107	NIPPLE, hex, 3/8 x 1/2	1
5	801-648	HEX PLUG, M24 x 2 x 16	6	26	801-523	NIPPLE, hex, 1/2 NPT x 2"	1
6	801-647	MANIFOLD	1	27	801-620	ELBOW, 1/4 NPT	1
7	801-479	HEAD RING	6	28	801-621	ELBOW, 1/4 x 1/2 NPT	1
8	801-478	PACKING	6	29	801-622	CROSS, 1/2 NPT	1
9	801-481	LONG LIFE RING	3	30	801-110	HOSE ADAPTER	1
10	801-476	O-RING	3	31	801-111	HOSE CONN. NUT	1
11	801-777	OIL SEAL	3	32	801-112	INLET SCREEN	1
12	801-493	PLUNGER RETAINING SCREW	3	33	801-597	HOSE, low pressure	1
13	801-492	BEARING/GASKET WASHER	3	34	801-623	HOSE, low pressure	1
14	801-475	OIL DIPSTICK	1	35	801-416	NIPPLE, 3/8 NPT x 3/4 NPT	1
15	801-489	FLINGER	3	36	801-625	VALVE, by-pass	1
16	801-490	PLUNGER	3	37	800-122	UNLOADER ASSEMBLY, see parts drawing/list page 8	1
17	801-491	BACK-UP RING	3	38	801-568	QUICK COUPLE, male, 3/8	1
18	801-488	O-RING	3	39	801-526	TENSIONER, belt	2
19	801-477	PACKING RETAINER	3	40	801-624	PUMP	1
20	801-480	INTERMEDIATE RING	3				
21	801-484	CAP, 3/8 NPT	1				

Order parts by name and series letter of the assembly for which you are ordering.

ACCESSORIES (Must be purchased separately)

CHEMICAL INJECTOR KIT 800-117

For injecting harsh cleaning chemicals downstream from pump.

BACK FLOW PREVENTOR 801-133

Prevent back-up of contaminated water into fresh supply. Install upstream from pump.

WATER SANDBLASTER 800-120

For abrasive cleaning of stubborn dirt and paint. Spray tip not included in kit.

SANDBLASTER SPRAY TIP 801-667

TECHNICAL DATA

ENGINE:	BRIGGS & STRATTON 4 cycle, two cylinder, air cooled, 18 hp
GASOLINE TANK:	3 gallon (11.36 liter) capacity
WATER PUMP:	5200 PSI (220 bar) max. pressure; 4.4 GPM (16.5 liter/min).
WETTED PARTS:	Stainless Steel, Aluminum, Phenolic Plastic, Ceramic Liners, Nitrile Rubber.
UNIT WEIGHT:	244 lb (111 kg)
OVERALL DIMENSION:	Length: 810 mm Width: 710 mm Height: 650 mm
MAX. WATER TEMPERATURE:	160° (70° C)
INLET HOSE CONNECTION:	3/4" garden hose (f)

THE GRACO WARRANTY

Graco Inc. warrants all equipment manufactured by it and bearing its name to be free from defects in material and workmanship under normal use and service. This warranty extends to the original purchaser for a period of 12 months from the date of purchase and applies only when the equipment is installed and operated in accordance with written factory recommendations. This warranty does not cover damage or wear which, in the reasonable judgment of Graco, arises from misuse, abrasion, corrosion, negligence, accident, substitution of non-Graco parts, faulty installation or tampering.

This warranty is conditioned upon the prepaid return of the equipment claimed to be defective for examination by Graco to verify the claimed defect. If the claimed defect is verified, Graco will repair or replace free of charge, any defective parts. The equipment will be returned to the original purchaser transportation prepaid. If inspection of the equipment does not disclose any defect in workmanship or material, repairs will be made at a reasonable charge and return transportation will be charged.

THIS LIMITED WARRANTY IS EXCLUSIVE, AND IS IN LIEU OF ANY OTHER WARRANTIES (EXPRESS OR IMPLIED) INCLUDING WARRANTY OF MERCHANTABILITY OR WARRANTY OF FITNESS FOR A PARTICULAR PURPOSE AND OF ANY NON-CONTRACTUAL LIABILITIES INCLUDING PRODUCT LIABILITIES BASED ON NEGLIGENCE OR STRICT LIABILITY. EVERY FORM OF LIABILITY FOR DIRECT, SPECIAL OR CONSEQUENTIAL DAMAGES OR LOSS IS EXPRESSLY EXCLUDED AND DENIED.

EQUIPMENT NOT COVERED BY GRACO WARRANTY. Accessories or components of equipment sold by Graco that are not manufactured by Graco (such as electric motors, switches, hose, etc.) are subject to the warranty, if any, of their manufacturer. Graco will provide purchaser with reasonable assistance in making such claims.

Factory Branches: Atlanta, Dallas, Detroit, Los Angeles, West Caldwell (N.J.)
Subsidiary and Affiliate Companies: Canada; England; Switzerland; France; Germany; Hong Kong; Japan
GRACO INC. P.O. BOX 1441 MINNEAPOLIS, MN 55440-1444